

## E Band Transmitter, 71-86GHz, Gain=15dB, Pout=+17dBm

2022-5-1

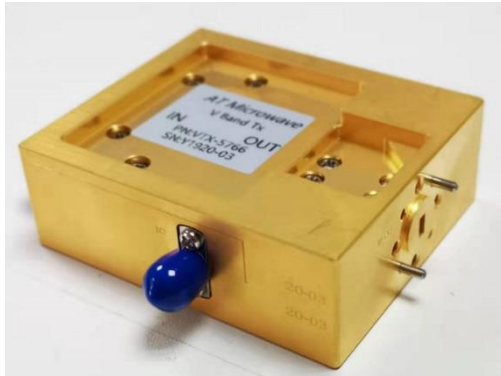

### Product Overview

AT-ETX-7186 is a E-Band Transmitter, with gain=15dB, Pout=+15dBm typical.

The Tx is integrated with High Performance GaAs MMIC chips. RF frequency range is 71-86GHz, LO range is 11.8-14.33GHz with x6 times multiplier inside. IF range is DC-10GHz The transmitter is with compact size. LO/IF port is with SMA, and RF port is with standard WR-12.

More information, please visit [www.atmicrowave.com](http://www.atmicrowave.com)

### Feature

- ✓ Frequency: 71-86GHz
- ✓ Gain: 15dB typical
- ✓ IF Range: DC-10GHz
- ✓ Pout: +15dBm Typical

### Application

- ✓ E Band Communication
- ✓ FOD (Foreigner Objects Debris)
- ✓ Test Equipment
- ✓ ROF (RF Over Fiber)
- ✓ Radar System

### Diagram Block

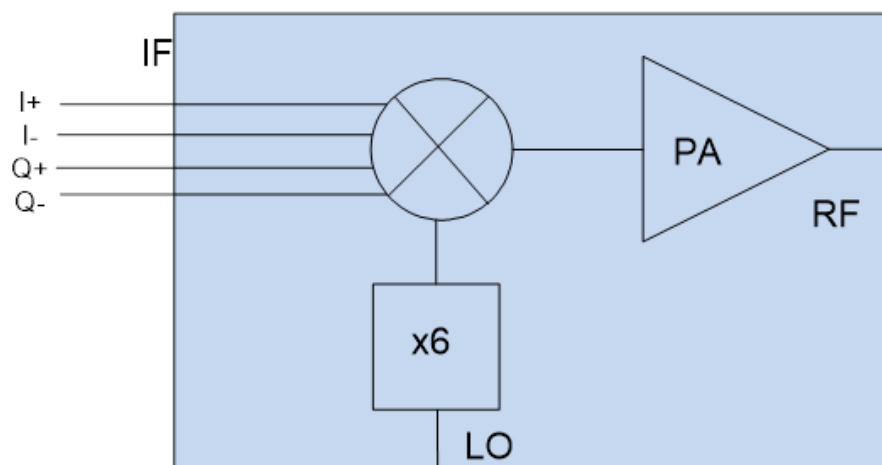



# AT-ETX-7186

Compact E Band Transmitter, 71-86GHz

## Key Features

Parameter	Min	Typical	Max
RF Frequency		71-86GHz	
IF Frequency (Note1)		DC-10GHz	
LO Frequency	11.3GHz		14.33GHz
Multiplier Factor		X6	
LO Power	+10dBm	+12dBm	+14dBm
P1dB		+15dBm	
Psat		+17dBm	
Conversion Gain		71-81GHz: 15 dB 81-86GHz: 12dB	
Single-side Band Rejection		-25dB	
LO Leakage Power(Note)		0dBm	
RF Return Loss		-10 dB	
LO Return Loss		-10 dB	
Drain Power Supply		+5/0.5A	+8V
RF Port Connector		WR-12	
IF/LO Port Connector		SMA Female	
Weight		310g	
Dimension		See outline	

Note: LO Power suppression can be improved by I+/I-/Q+/Q- dc offset calibration.





# AT-ETX-7186

Compact E Band Transmitter, 71-86GHz

## Absolute Maximum Ratings Table

Parameter	Value
Drain Supply	+9V
If Input Power per/Channel	+7dBm
LO Power	+15dBm
Operating Temperature	0 to +50C
Storage Temperature	-65 to +150C

## Test Condition

Parameter	Setting
IF Input Power	0dBm
Input Frequency	1GHz
LO Power	+10dBm
Temperature	25C

## Test Data:

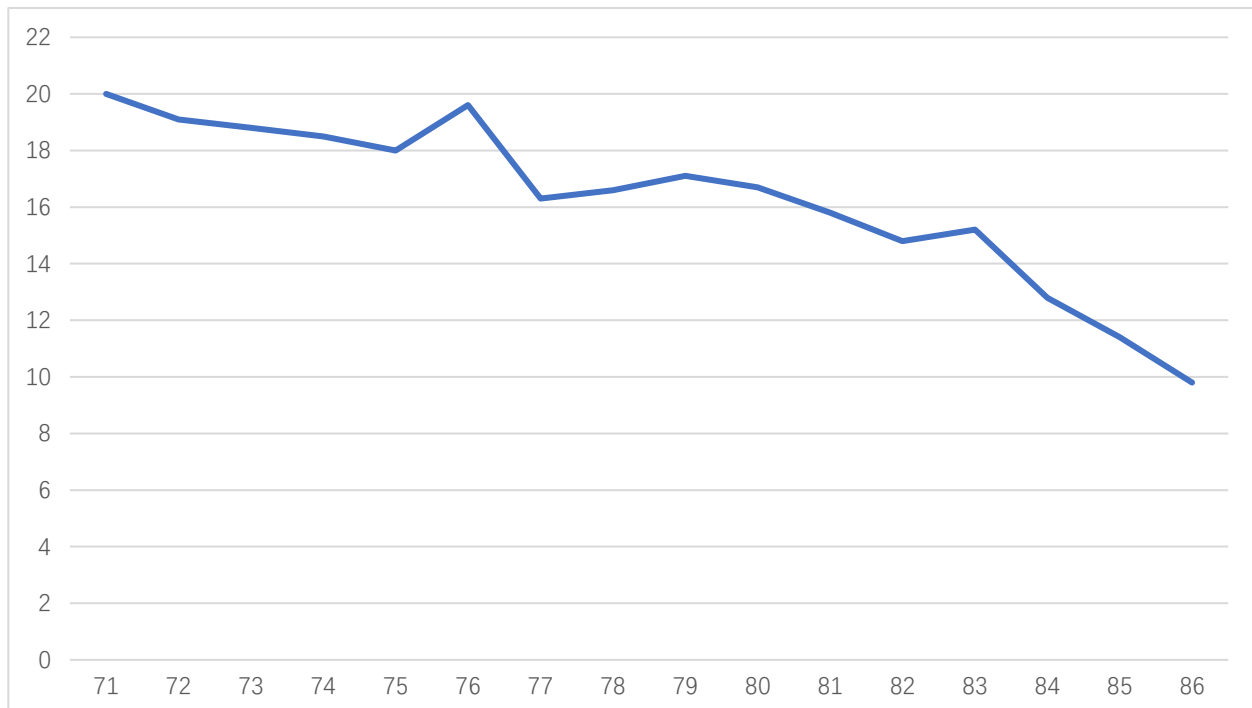

Conversion Gain vs Frequency



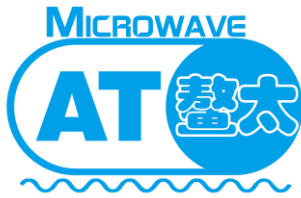

# AT-ETX-7186

Compact E Band Transmitter, 71-86GHz

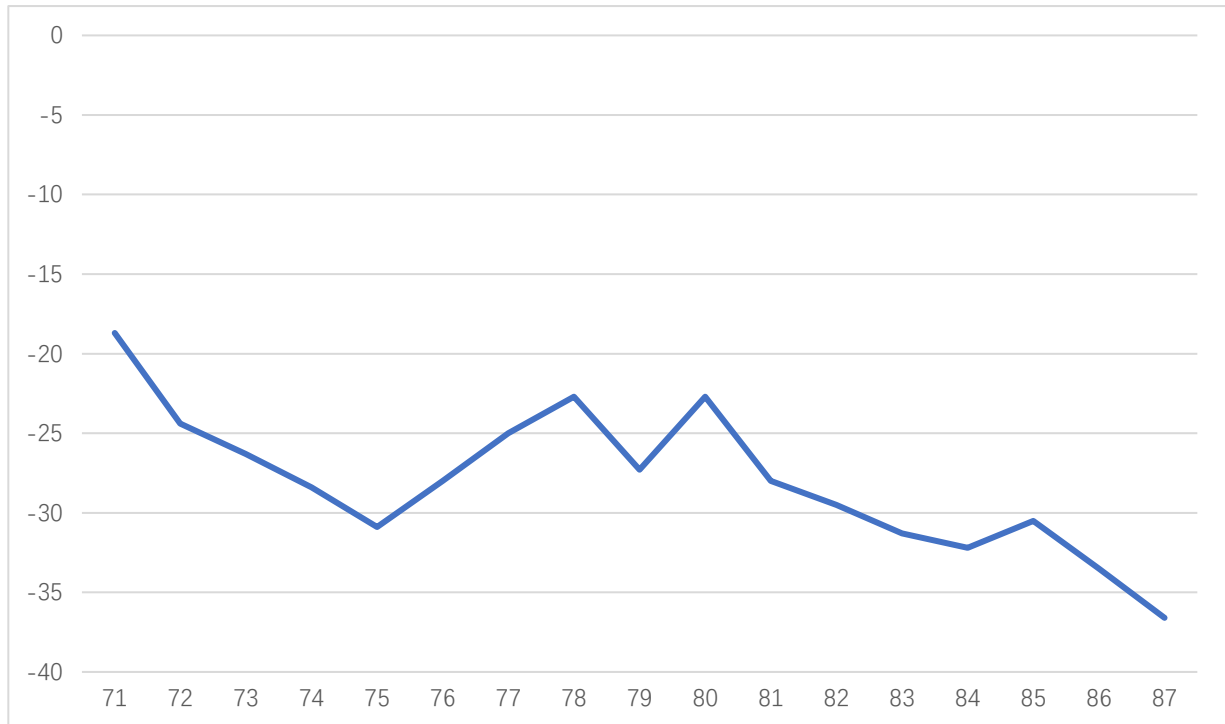

Low band side Rejection, IF=1GHz

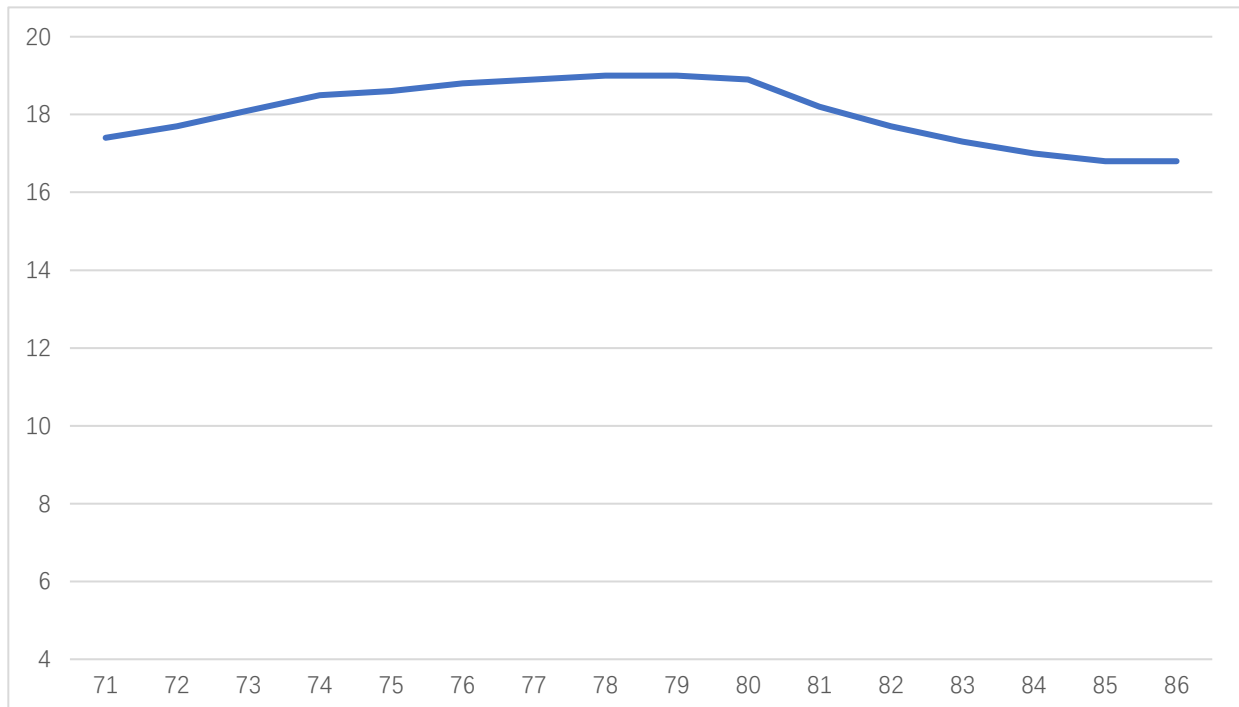

Psat vs Frequency, IF=1GHz



### Application Note

Mixer is a three port component with RF, LO and IF ports. Normally, a mixer can be used both up and down converter application. Take up converter for example:

#### General Balance Mixer

For general balance mixer,  $RF = LO \pm IF$ . There will be both high end  $LO+IF$  and Low End  $LO-IF$ . Take for example,  $IF=2GHz$ ,  $LO=80GHz$ , so there will be  $78GHz$  and  $82GHz$  at RF port with same power level.

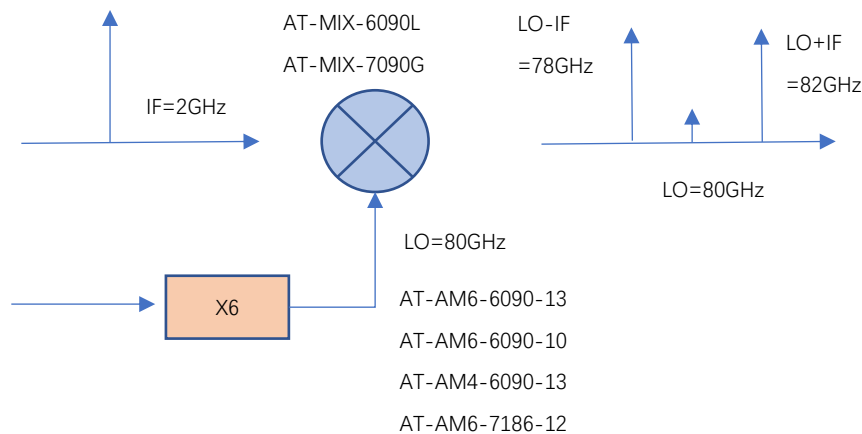

Figure A: General Balance Mixer with Both High and Low Side Output

#### IQ Mixer used as side suppression Mixer

When  $IF=2GHz$ , 90 degree hybrid is used at IF port, and IF applies to Input 1 Port of hybrid, you will have high end frequency  $RF = LO + IF = 82GHz$ , while have side suppression (say  $-25dBc$ ) at Low end frequency  $78GHz$ .

When you need low end frequency  $78GHz$ , and make side suppression for high end frequency  $82GHz$ , just applies IF to Input 2 of the hybrid.

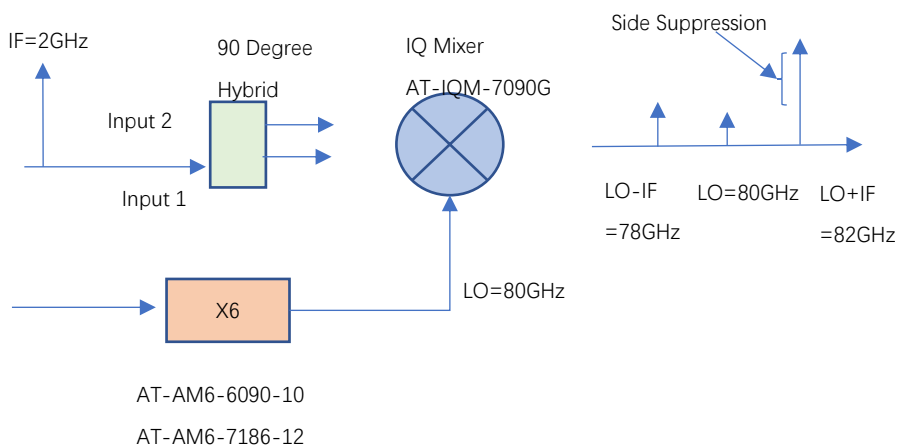

Figure B: IQ Mixer works as side suppression mixer



